



ECIT
MOTOR GROUP

Compliance Presentation for NHTSA



Low-Volume Motor Vehicle Manufacturers Act of 2015



MOTOR GROUP

(16) “Specially produced motor vehicle” or “SPMV” means a newly produced current model year passenger car or light-duty truck, with a gross vehicle weight rating (GVWR) at or below 8,500 pounds, that meets all of the following requirements:

Our vehicle is a SPMV current model year (2024) passenger car that will be approximately 3500 pounds.



MOTOR GROUP

- (A) Resembles the body of a motor vehicle, on an overall 1:1 scale (+/- 10 percent) of original body lines, excluding roof configuration, ride height, trim attached to the body, fenders, running boards, grille, hood or hood lines, windows, and axle location, that had been commercially manufactured during consecutive model years, for sale not less than 25 years after the latest model year, with a production run of at least 50 units of a unique body style, before production of the current model year motor vehicle;

| | C3 Corvette | Ecite EV-C3 | Dfferance | % |
|----------------|--------------------|--------------------|------------------|----------|
| Length | 184.7 | 190 | 5.3 | 2.9% |
| Height | 47.8 | 48 | 0.2 | 0.4% |
| Width | 69 | 76 | 7 | 10.1% |
| OVERALL | | | | 4.5% |



EXCITE

MOTOR GROUP

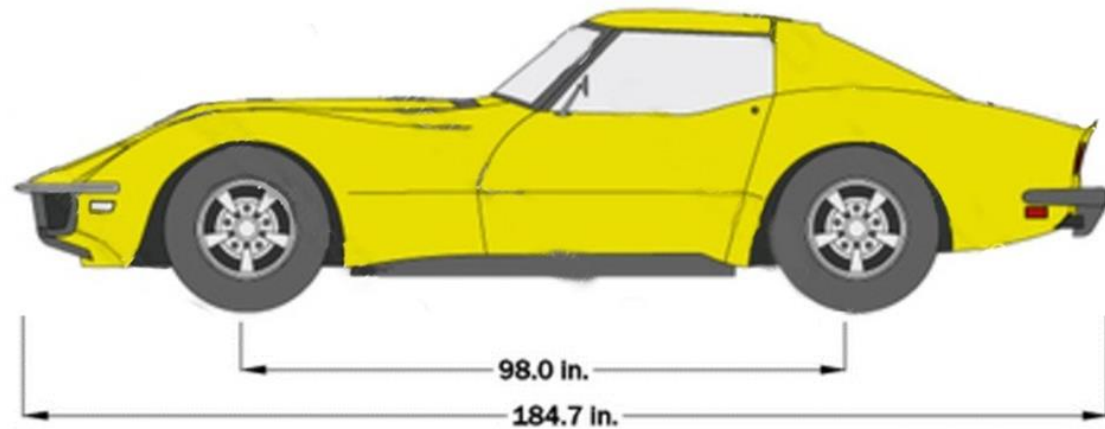
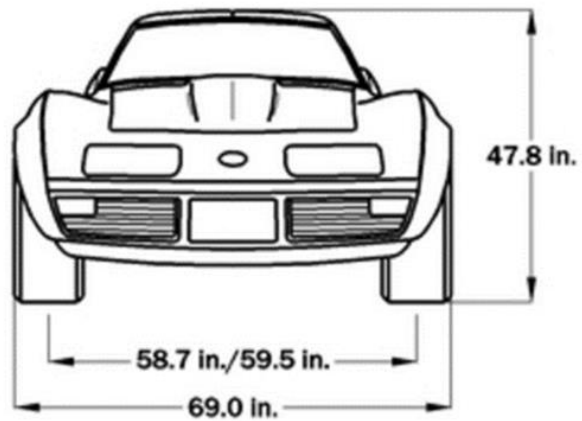
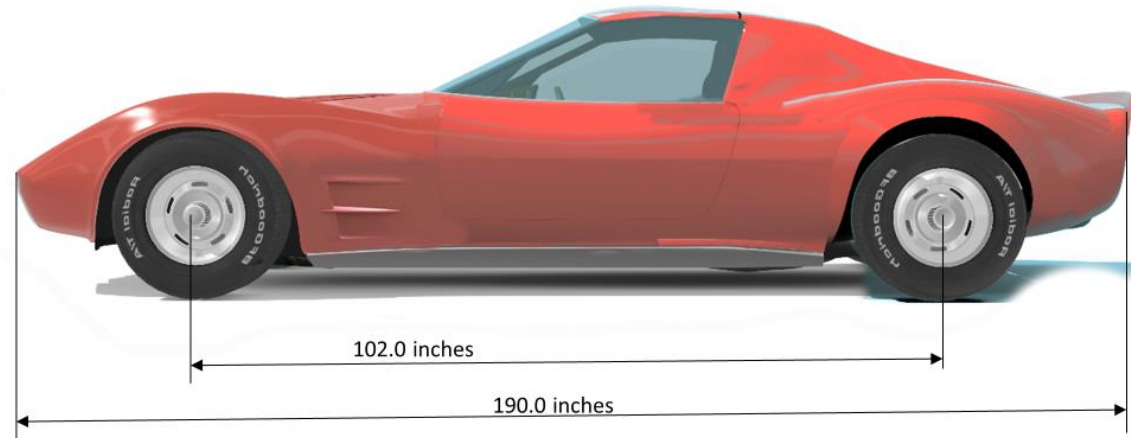
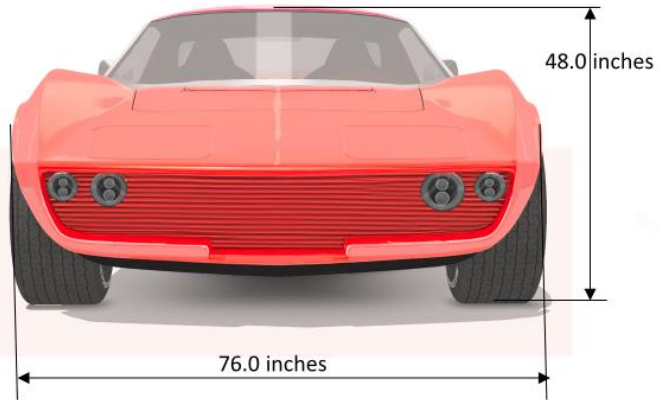



ECITE

MOTOR GROUP

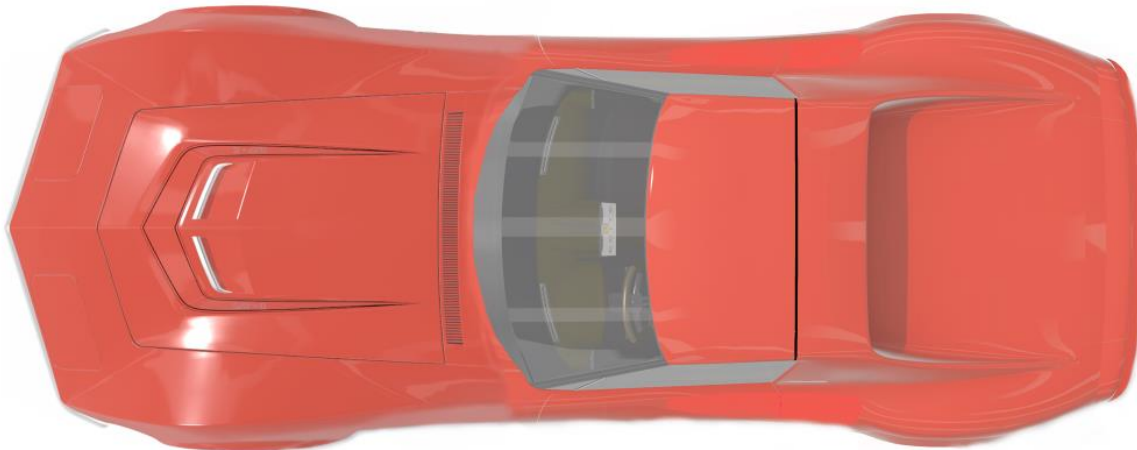
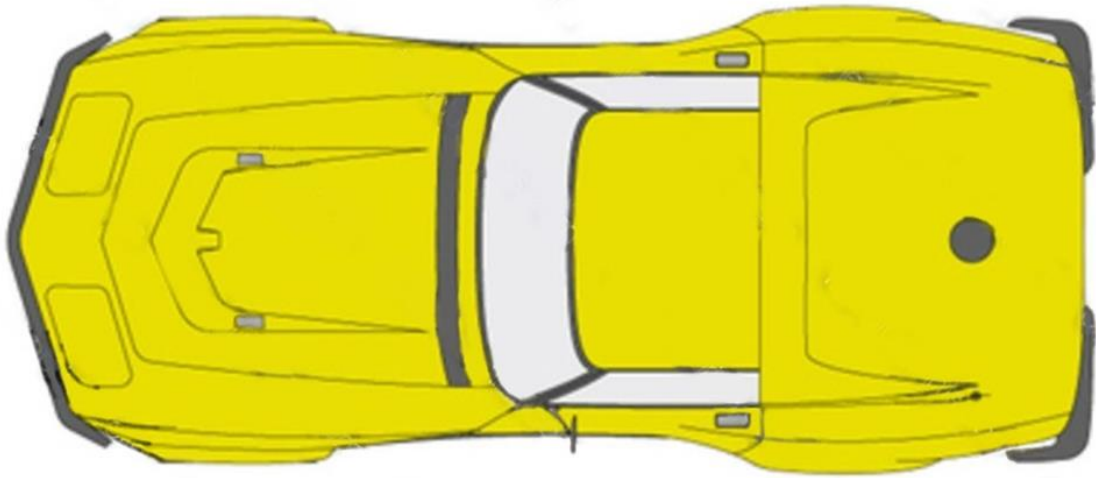



EECIT E
MOTOR GROUP

(A) continued

We have designed a vehicle that represents the 1968 to 1977 C3 Corvette vehicle with cosmetic changes and lighting changes. We have increased the wheelbase for stability and safety. We have increased the height and width of the car for stability, comfort and safety of the vehicle. We have designed an electric drive-train for this vehicle for the environment and to meet emissions standards. We have designed our own unique aluminum chassis which holds the electric drive-train. We are looking forward to proceeding with our design, prototype and production build of this new vehicle.



E C I T E

MOTOR GROUP

(B) Meets any applicable National Highway Traffic and Safety Administration (NHTSA) provisions requiring the vehicle to be manufactured under a license agreement for the intellectual property rights for the replicated vehicle from the original manufacturer or its current owner, successor or assignee, as determined by NHTSA;



E-Cite Motors, L.L.C. has consulted with numerous attorneys and industry experts in order to ensure that it possesses any and all possible intellectual rights required to legally manufacture a motor vehicle that "resembles" a 1968-1977 C-3 Chevrolet Corvette.

E-Cite Motors hereby certifies that based on extensive research and analysis of the relevant laws and legal precedents, E-Cite Motors Group, L.L.C. has the legal right to manufacture a replica of a 1968-1977 Chevrolet Corvette without infringing on any intellectual property rights of Chevrolet nor any other entity nor person, or engaging in any unfair competition practices.

Our certification is based on the following findings:

1. Chevrolet nor any other entity nor person holds any US design patents for the design of the 1968-1977 Chevrolet Corvette. US design patents only provide a limited period of protection, only 15 years from the date of grant. Once the design patent expires, it cannot be used to enforce rights against those who would copy the design. Any and all Design patents covering the 1968-1977 Corvette would have expired in 1983 at the latest. More than 41 years beyond that point have passed. Therefore, E-Cite Motors Group, L.L.C. has the right to manufacture a replica of the car without infringing on any patent rights.
2. Chevrolet nor any other entity nor person has any trade dress protection for the 1968-1977 Chevrolet Corvette. Trade dress infringement occurs when an alleged infringer makes use of a protectable and similar automobile design, which creates a likelihood of confusion as to the association, affiliation, or sponsorship of the infringer's automobile design. Factors included in this "likelihood of confusion" determination include (a) the similarity of the trade dresses, (b) the area and manner of concurrent use, including the similarity of the automobiles on which the trade dresses are being used, (c) the degree of care likely to be used by consumers, (d) the strength of the mark owner's trade dress, (e) evidence, if any, of actual confusion, and (f) any intent on the part of the alleged infringer to pass off its automobile as that of the trade dress owner. However, the general design of the Corvette is not generally recognizable to the consumer as a Chevrolet, and there is no likelihood that any consumer would be confused that the E-Cite C3 was manufactured by Chevrolet. E-Cite does not intend to pass the E-Cite C3 off as a Corvette nor is there any reasonable assumption nor that there could ever be any confusion between the two. Furthermore, the Corvette has not under any reasonable criteria as defined by the courts acquired "secondary meaning" I legalese terminology meaning that the consuming public will be able to recognize the source of an automobile by the design only. Therefore, E-Cite Motors Group, L.L.C. has the right to manufacture a replica of the car without infringing on any trade dress rights.
3. Consumers would likely be able to tell the difference between a Chevrolet Corvette and an E-Cite C3. Therefore, E-Cite Motors Group, L.L.C. has the right to manufacture a replica of the car without engaging in any unfair competition or trademark infringement.

Based on the above findings, I hereby certify that E-Cite Motors Group, L.L.C. undeniably possesses any and all conceivable rights that may be required to manufacture a vehicle that is different yet "resembles" a 1968-1977 Chevrolet Corvette and does not infringe on any intellectual property rights or engage in any unfair competition practices.

Vaporbrands International, Inc.

By:

Barry Henthorn
Chief Executive Officer & Director



€ C I T €
MOTOR GROUP

(B) continued

- ❖ We have consulted with numerous attorneys and industry experts in order to ensure that it possesses any and all possible intellectual rights required to legally manufacture a motor vehicle that “resembles” a 1968 to 1977 C3 Corvette. (see attached letter)
- ❖ The 1968 to 1977 C3 Corvette does NOT hold any IP or trademarks on the Body of its vehicle only its badging
- ❖ We certify that we have the rights to build this rendition of the 1968 to 1977 C3 Corvette.
- ❖ Our vehicle is similar to the 1968 to 1977 C3 Corvette but will NOT have badges, decals, or identifiers that are held by IP or trademark. Our vehicle resemble these Iconic classic vehicles in a method of homage, badged by our own company not that of an existing OEM.
- ❖ We as a manufacturer wish to create beautiful cars of the past, resembling vintage autos without portraying that it is a copy. That it resembles the styling ques with today's technology and safety.



E C I T E
MOTOR GROUP

(C) Meets any applicable NHTSA requirements regarding vehicle safety, as determined by NHTSA;

Ecite Motors Group will meet or exceed any and all NHTSA requirements under the low-volume motor vehicle act regarding vehicle safety.



ECITE
MOTOR GROUP

(D) SPMVs are subject to state titling and registration laws and regulations, including smog check and emissions compliance, and must consider the following:

1. Subject to smog check requirements starting with registrations first made or renewed on or after January 1, 2019.

Ecite Motors Group understand the state titling and registration laws and Regulations, including smog check and emissions compliance.

We have designed our own unique aluminum chassis which holds an all-electric drive-train.



E C I T E
MOTOR GROUP

2. A SPMV shall be treated as a new vehicle for purposes of smog check, resale and previously registered outside the state shall be subject to a smog check inspection upon registration.
3. SPMV manufacturer's name must be listed in state titling and registration information.

Ecite Motors Group is a new car manufacturer and holds all the approvals and documentation for registering a vehicle, including creating the new VIN.

E-Cite Motors Group WMI Code is 1V9 which will be positions 1,2, and 3 of the VIN of all E-Cite Motors passenger vehicles. The vehicle production number will occupy positions 12, 13, and 14 of all E-Cite Motors passenger vehicles.

E-Cite Motors Group Manufacturers ID 21725 was issued currently with 000 motor vehicles.



E C I T E
MOTOR GROUP



July 21, 2022

Gene Langmesser
dba E-cite Motors Group
Vaporbrands International Inc.
15812 116th Ave NE
Bothell WA 98011-4103

Dear Gene Langmesser,

As the agent of the National Highway Traffic Safety Administration for the assignment of manufacturer identifiers pursuant to CFR 49 Part 565 Vehicle Identification Number Requirements (VIN), the following World Manufacturer Identifier (WMI) Code has been reserved:

| | | |
|---------------|--|------------------------------------|
| WMI Code | 1V9 | Positions 1, 2 & 3 of VIN |
| WMI Extension | 255 | Positions 12th, 13th & 14th of VIN |
| Manufacturer | Vaporbrands International Inc. dba E-cite Motors Group 15812 116th Ave NE Bothell WA 98011-4103 | |
| Country | United States | |
| Vehicle Type | Passenger Car - Replica | |
| Make/Model | E-cite Motors - 1972 Ferrari Dino GTS, C2 Corvette, Jaguar XL 220 | |

If changes occur, such as company name, ownership, address and/or phone number, please be sure to notify us as soon as possible.

If you have questions concerning the construction of your Vehicle Identification Number, please contact the National Highway Traffic Safety Administration (NHTSA) Crash Data and Manufacturer Hotline at:

Email: manufacturerinfo@dot.gov
Phone: 1-888-399-3277
Fax: 1-202-366-1024

Thank you.

Sincerely,

Kris Siddall
CSR / WMI Coordinator



ECITE
MOTOR GROUP

Ecite Motors EV- C3

Chassis, Drivetrain & Interior

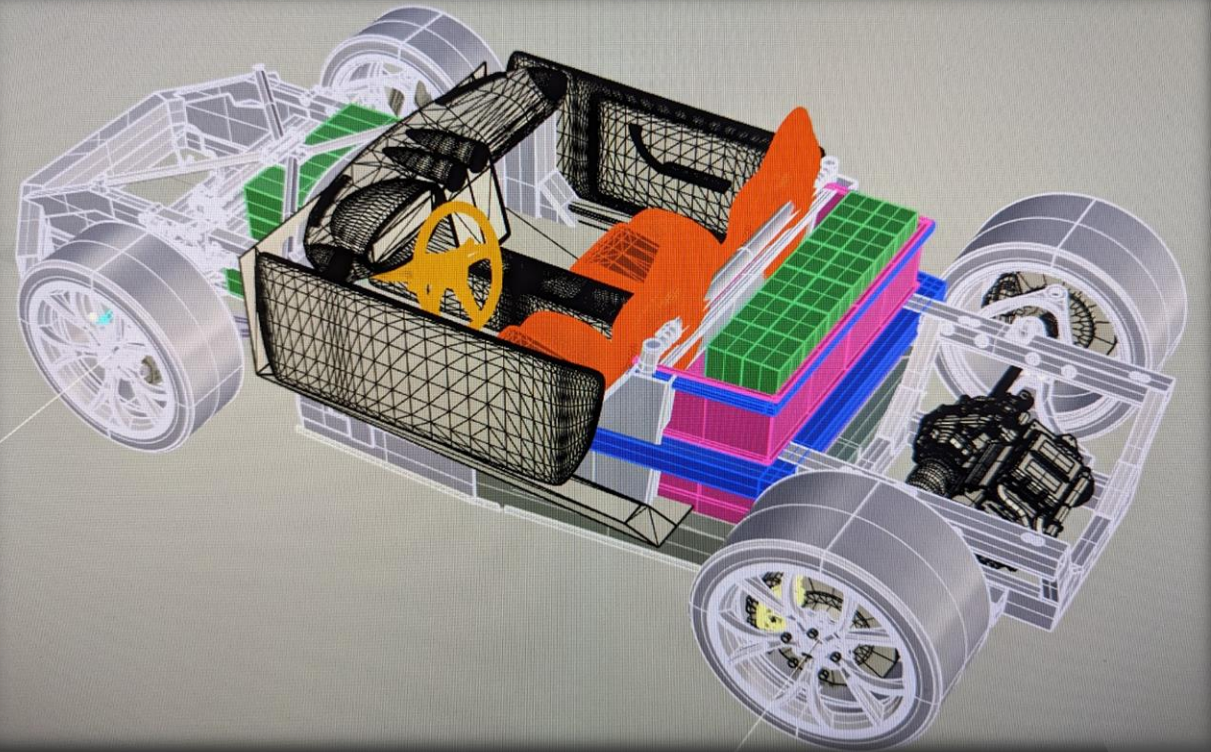
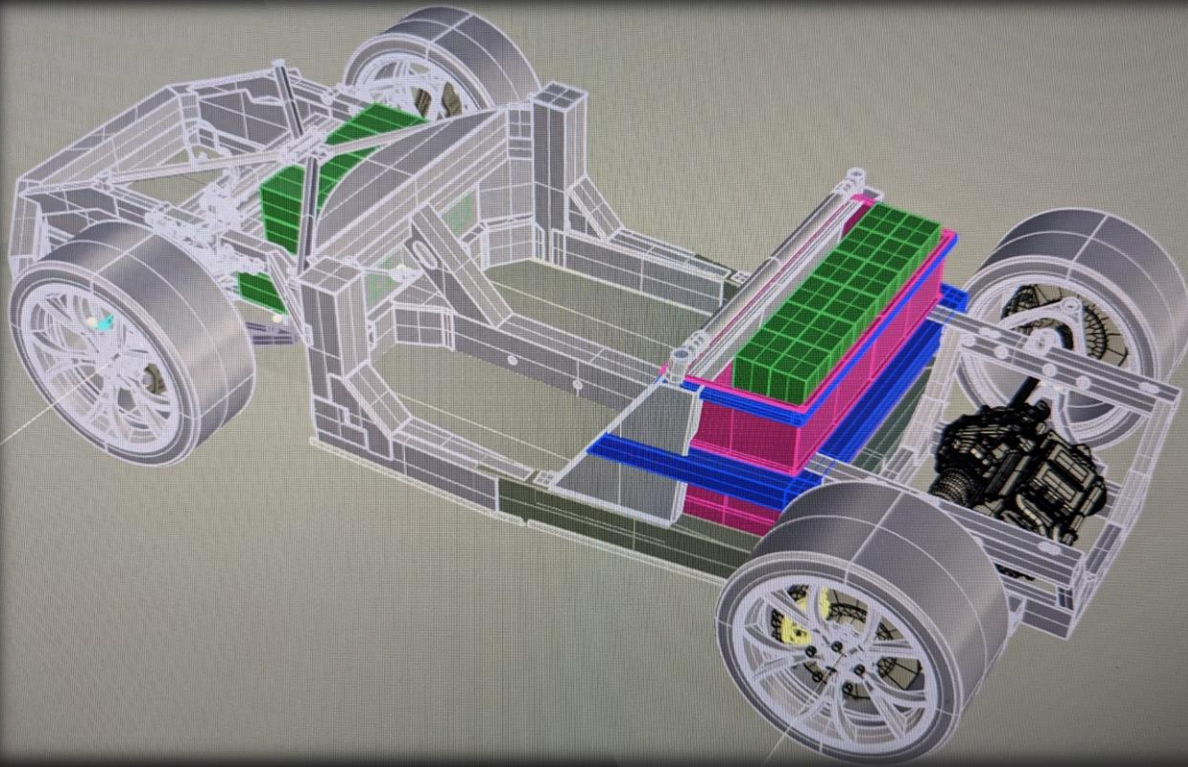



ECI T E

MOTOR GROUP

Thank You